

QLogic 10Gb CNA for IBM System x and IBM Power Systems

IBM System x at-a-glance guide

The QLogic 10Gb CNA is a PCI Express 2.0 x4 10Gb Converged Network Adapter and is available for both IBM System x and IBM Power Systems servers. For IBM Power Systems, the adapter is known as the 10 Gb FCoE PCIe Dual Port Adapter (Feature 5708). The adapter connects to SFP+ Multimode Fiber SR optical modules. The System x version also supports SFP+ Active Copper cables, depending on the Ethernet switch used.

This adapter supports 10 Gbps per port maximum bidirectional throughput for high-bandwidth storage (SAN) and networking (LAN) traffic, with full hardware offload for Fibre Channel over Ethernet (FCoE) protocol processing. The QLogic 10Gb CNA is shown in Figure 1.

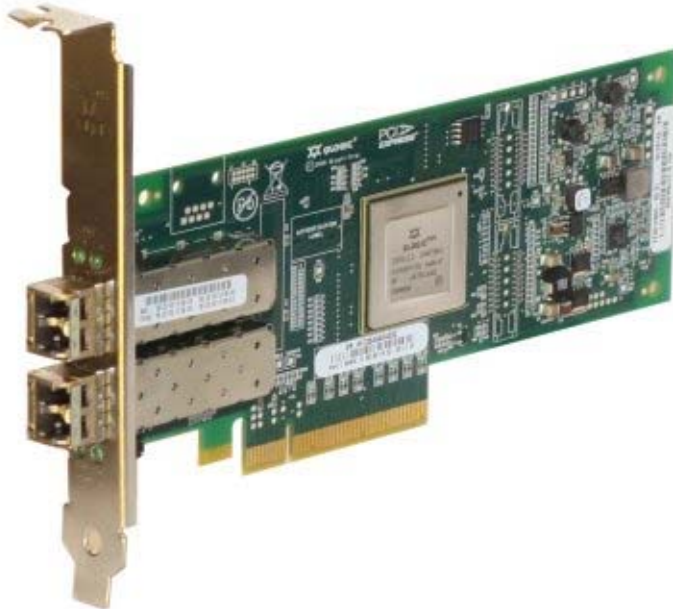

Figure 1. QLogic 10Gb CNA

Did You Know?

Convergence of SAN and LAN traffic on a single adapter and wire helps lower the total cost of ownership by reducing the reduced hardware, power, cooling, management, and maintenance costs. It offers investment protection by providing seamless compatibility with existing Fibre Channel (FC) Storage, ethernet networks, driver software, and management applications.

Part number information

Table 1. Ordering part number and feature code

Description	Option part number	Feature code
QLogic 10Gb CNA for IBM System x	42C1800	5751
QLogic 10Gb CNA for IBM Power Systems (Feature 5708, 10 Gb FCoE PCIe Dual Port Adapter)	Not applicable	5708
QLogic 10Gb SFP+ SR Optical Transceiver*	49Y4218	0064

* This transceiver is standard with the Power Systems feature 5708

Part number 42C1800 includes the following items:

- One QLogic 10Gb CNA for IBM System x
- 2U bracket
- Support CD
- Safety flyer

Transceiver part number 49Y4218 includes the following items:

- One QLogic 10Gb SFP+ SR Optical Transceiver
- Support CD
- Safety flyer

Note: The transceiver is not included with part number 42C1800 or System x feature 5751, however it is included with Power Systems feature 5708.

Features

The QLogic 10Gb CNA has the following features:

- PCI Express 2.0 compliance
- Operates at PCI Express 2.0 x4 or PCI Express 1.1 x8
- Transceiver support:
 - System x option: Two SFP+ cages for either SFP+ Fiber SR or SFP+ Active Copper
 - Power Systems feature: Two QLogic 10Gb SFP+ SR Optical Transceivers standard
- Standard PCI Express half length card with low profile form factor
- Support for both standard PCI-E slot and low profile PCI-E slot (System x option only)
- Support for 10Gb Converged Enhanced Ethernet (CEE)
- Support for Fibre Channel over Converged Enhanced Ethernet (FCoCEE)
- Full hardware offload for FC protocol processing
- Support for IPv4 and IPv6
- Support for SAN boot over CEE and iSCSI boot

Note: There is no support for PXE boot.

The QLogic 10Gb SFP+ SR Optical Transceiver has the following features:

- Laser Class 1 compliance
- Support for the SFP+ cages on the 42C1800 adapter
- Standard SFP+ form factor for multimode Fiber SR

Ethernet specifications

The QLogic 10Gb CNA has the following Ethernet specifications:

- Throughput: 10 Gbps full duplex line rate per port
- Topology: Any 10Gb Ethernet Network
- Ethernet Frame: 1500 byte or 9000 byte (Jumbo Frame)
- Stateless offload features:
 - IP, TCP, and UDP checksum offloads
 - Large and Giant Send Offload (LSO, GSO)
 - Receive Side Scaling (RSS)
 - Header-data split
 - Interrupt coalescing
 - NetQueue
- Enhanced Ethernet features:
 - Priority-based flow control (802.1Qbb rev. 0)
 - Enhanced transmission selection (802.1Qaz rev. 0)
 - DCBX protocol (802.1Qaz rev. 0)
- Compliance
 - IEEE: 802.3ae (10Gb Ethernet)
 - 802.1q (VLAN)
 - 802.3ad (Link Aggregation)
 - 802.1p (Priority Encoding)
 - 802.3x (Flow Control)
 - 802.3ap (KX/KX4)
 - 802.3ak (CX4)
 - IEEE 1149.1 (JTAG)
 - IPv4 Specification (RFC 791)
 - IPv6 Specification (RFC 2460)
 - TCP/UDP Specification (RFC 793/768)
 - ARP Specification (RFC 826)

FCoE specifications

The QLogic 10Gb CNA has the following FCoE specifications:

- Performance: 250,000 IOPS per port
- Logins: Support for 2048 concurrent logins and 2048 active exchanges
- Class of service: Class 3
- Protocols: FCP (SCSI-FCP), FC-TAPE (FCP-2)

- Compliance:
 - SCSI-3 Fibre Channel Protocol (SCSI-FCP)
 - Fibre Channel Tape (FC-TAPE) profile
 - SCSI Fibre Channel Protocol-2 (FCP-2)
 - Second Generation FC Generic Services (FC-GS-2)
 - Third Generation FC Generic Services (FC-GS-3)

Operating environment

The adapter is supported in this environment:

- Temperature:
 - Operating: 0° to 55°C (32° to 113°F) at 0 to 914 m (0 to 3000 ft)
 - Storage: -43° to 73°C (-40° to 163°F) at 0 to 914 m (0 to 3000 ft)
- Relative humidity: 5% to 93% (non-condensing)

Supported servers

The QLogic 10Gb CNA for IBM System x is supported in the IBM System x servers listed in Table 2.

Table 2. Supported System x servers (Part 1)

Adapter	Part number	x3100 M3	x3200 M2	x3200 M3	x3250 M2	x3250 M3	x3350	x3400	x3400 M2	x3400 M3	x3455	x3500	x3500 M2	x3500 M3
QLogic 10Gb CNA for IBM System x	42C1800	N	Y	Y	Y	Y	Y	Y	Y	Y	Y	Y	Y	Y

Table 2. Supported System x servers (Part 2)

Adapter	Part number	x3550	x3550 M2	x3550 M3	x3620 M3	x3650	x3650 T	x3650 M2	x3650 M3	x3655	x3690 X5	x3755	x3850 M2	x3950 M2	x3850 X5
QLogic 10Gb CNA for IBM System x	42C1800	Y	Y	Y	Y	Y	Y	Y	Y	Y	Y	Y	Y	Y	Y

See IBM ServerProven for the latest information on the System x servers that support this adapter:
<http://ibm.com/servers/eserver/serverproven/compat/us/>

The QLogic CNA is supported in the IBM Power Systems servers listed in Table 3.

Table 3. Supported Power Systems servers

Adapter	Feature code	Power 520	Power 550	Power 560	Power 570	Power 575	Power 595	Power 750	Power 755	Power 770	Power 780
QLogic 10Gb CNA for IBM Power Systems (10 Gb FCoE PCIe Dual Port Adapter)	5708	Y	Y	Y	Y	Y	Y	Y	Y	Y	Y

Supported connectivity

The QLogic 10Gb CNA supports the QLogic 10Gb SFP+ SR Optical Transceiver listed in Table 1. The transceivers are standard on the QLogic 10Gb CNA for IBM Power Systems, feature code 5708.

Active copper cables (also known as Twinax Active cables, or Direct-attach copper or DAC cables) are also supported on the adapter for System x servers, but that support also depends on the switch that the cable also connects to. Table 4 lists the supported cables where the combination of the QLogic 10Gb CNA for System x and the specific switch has been tested.

Note: Direct-attach copper cables are not supported by the QLogic 10Gb CNA for IBM Power Systems, feature code 5708.

Table 4. Supported Active copper cables

	Twin-ax Active 1 m 45W2398 (1-pack) 45W2401 (8-pack)	Twin-ax Active 3 m 45W2408 (1-pack) 45W2409 (8-pack)	Twin-ax Active 5 m 45W3039 (1-pack) 45W3042 (8-pack)
IBM Converged Switch B32	Yes	Yes	Yes
Cisco Nexus 5010	Yes	Yes	Yes
Cisco Nexus 5020	Yes	Yes	Yes
Brocade 8000	Yes	Yes	Yes

Popular configurations

This section illustrates how the QLogic 10Gb CNA for IBM System x can be used in configurations.

Figure 2 shows QLogic 10Gb CNA installed in a supported x3650 M2 server. The server is connected to the IBM System Storage DS4700 via two IBM Converged Switch B32 switches.

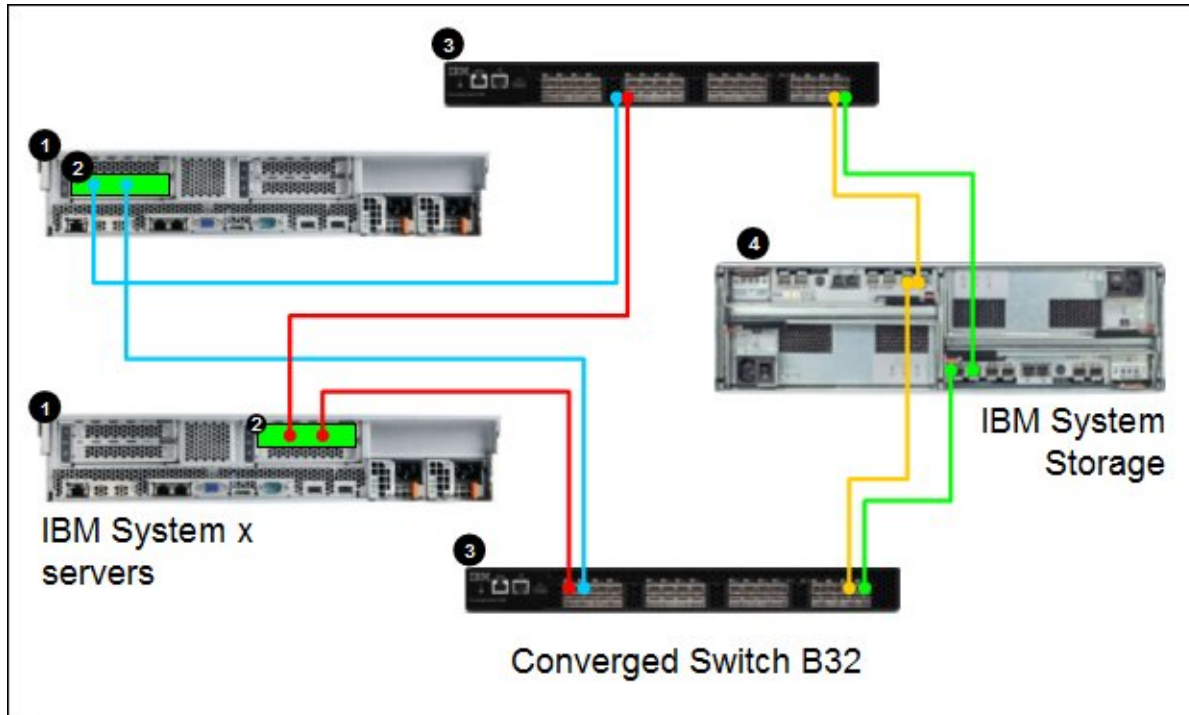

Figure 2. x3650 M2 server with the QLogic 10Gb CNA connected the IBM System Storage DS4700

The parts used are listed in Table 4.

Table 4. Components used when connecting QLogic 10Gb CNA to external disk storage (Figure 2)

Diagram reference	Part number/machine type	Description	Quantity
1	Varies	x3650 M2 or other supported server (See Table 2)	2
2	42C1800	QLogic 10Gb CNA for IBM System x	2
2	49Y4218	QLogic 10Gb SFP+ SR Optical Transceiver	4
3	3758-B32	IBM Converged Switch B32	2
4	1814-70A or 1814-70H	IBM System Storage DS4700 (Model 70 or Model 72)	1

This configuration also requires cabling between the servers and the IBM Converged Switches B32 and between the IBM Converged Switches B32 and storage system. (The cable part numbers are not listed in Table 4.)

Supported operating systems

The QLogic 10Gb CNA for IBM System x supports the following operating systems:

- Microsoft Windows Server 2003/2003 R2, Datacenter Edition
- Microsoft Windows Server 2003/2003 R2, Datacenter x64 Edition
- Microsoft Windows Server 2003/2003 R2, Enterprise Edition
- Microsoft Windows Server 2003/2003 R2, Enterprise x64 Edition
- Microsoft Windows Server 2003/2003 R2, Standard Edition
- Microsoft Windows Server 2003/2003 R2, Standard x64 Edition
- Microsoft Windows Server 2003, Web Edition
- Microsoft Windows Small Business Server 2003/2003 R2 Premium Edition
- Microsoft Windows Small Business Server 2003/2003 R2 Standard Edition
- Microsoft Windows Server 2008, Datacenter x64 Edition
- Microsoft Windows Server 2008, Datacenter x86 Edition
- Microsoft Windows Server 2008, Enterprise x64 Edition
- Microsoft Windows Server 2008, Enterprise x86 Edition
- Microsoft Windows Server 2008, Standard x64 Edition
- Microsoft Windows Server 2008, Standard x86 Edition
- Microsoft Windows Server 2008, Web x64 Edition
- Microsoft Windows Server 2008, Web x86 Edition
- Microsoft Windows Essential Business Server 2008 Premium Edition
- Microsoft Windows Essential Business Server 2008 Standard Edition
- Red Hat Enterprise Linux 5 Server Edition
- Red Hat Enterprise Linux 5 Server Edition with Xen
- Red Hat Enterprise Linux 5 Server x64 Edition
- Red Hat Enterprise Linux 5 Server with Xen x64 Edition
- SUSE LINUX Enterprise Server 11 for AMD64/EM64T
- SUSE LINUX Enterprise Server 11 for x86
- SUSE LINUX Enterprise Server 11 with Xen for AMD64/EM64T
- SUSE LINUX Enterprise Server 11 with Xen for x86
- SUSE LINUX Enterprise Server 10 for AMD64/EM64T
- SUSE LINUX Enterprise Server 10 for x86
- SUSE LINUX Enterprise Server 10 with Xen for AMD64/EM64T
- SUSE LINUX Enterprise Server 10 with Xen for x86

See IBM ServerProven at <http://ibm.com/servers/eserver/serverproven/compat/us/> for the latest information about the specific versions and service packs supported.

The QLogic 10Gb CNA for IBM Power Systems (feature 5708) supports the following operating systems:

- AIX 5.3 with the 5300-11 Technology Level, or later
- AIX 6.1 with the 6100-04 Technology Level, or later
- SUSE Linux Enterprise Server 10 Service Pack 3 or later
- Red Hat Enterprise Linux 5.4 or later
- VIOS 2.1.2.0 (also for IBM i support)

Note: IBM i support is limited to Ethernet traffic only

Related publications

For more information refer to these documents:

- 10Gb CNAs for IBM System x product page
<http://ibm.com/systems/storage/product/systemx/cna>
- *QLogic 10Gb CNA for IBM System x Installation and User's Guide* (You will need to download the "publication release" EXE file and run it to unpack the PDF)
<http://www.ibm.com/support/docview.wss?uid=psg1MIGR-5081072>
- Software and firmware for the adapter (QLE8142)
http://driverdownloads.qlogic.com/QLogicDriverDownloads_UI/Product_detail_new.aspx?oemid=395
- IBM US Announcement Letter for the QLogic 10Gb CNA for IBM System x
<http://ibm.com/common/ssi/cgi-bin/ssialias?infotype=dd&subtype=ca&&htmlfid=897/ENUS109-333>
- IBM US Announcement Letter for the QLogic 10Gb CNA for IBM Power Systems
<http://ibm.com/common/ssi/cgi-bin/ssialias?infotype=dd&subtype=ca&&htmlfid=897/ENUS109-571>
- IBM System x Configuration and Options Guide
<http://www.ibm.com/support/docview.wss?uid=psg1SCOD-3ZVQ5W>
- IBM Redbooks paper, *IBM Converged Switch B32*, REDP-4588
<http://www.redbooks.ibm.com/abstracts/redp4588.html?Open>

Notices

This information was developed for products and services offered in the U.S.A.

IBM may not offer the products, services, or features discussed in this document in other countries. Consult your local IBM representative for information on the products and services currently available in your area. Any reference to an IBM product, program, or service is not intended to state or imply that only that IBM product, program, or service may be used. Any functionally equivalent product, program, or service that does not infringe any IBM intellectual property right may be used instead. However, it is the user's responsibility to evaluate and verify the operation of any non-IBM product, program, or service. IBM may have patents or pending patent applications covering subject matter described in this document. The furnishing of this document does not give you any license to these patents. You can send license inquiries, in writing, to:

IBM Director of Licensing, IBM Corporation, North Castle Drive, Armonk, NY 10504-1785 U.S.A.

The following paragraph does not apply to the United Kingdom or any other country where such provisions are inconsistent with local law: INTERNATIONAL BUSINESS MACHINES CORPORATION PROVIDES THIS PUBLICATION "AS IS" WITHOUT WARRANTY OF ANY KIND, EITHER EXPRESS OR IMPLIED, INCLUDING, BUT NOT LIMITED TO, THE IMPLIED WARRANTIES OF NON-INFRINGEMENT, MERCHANTABILITY OR FITNESS FOR A PARTICULAR PURPOSE. Some states do not allow disclaimer of express or implied warranties in certain transactions, therefore, this statement may not apply to you. This information could include technical inaccuracies or typographical errors. Changes are periodically made to the information herein; these changes will be incorporated in new editions of the publication. IBM may make improvements and/or changes in the product(s) and/or the program(s) described in this publication at any time without notice.

Any references in this information to non-IBM Web sites are provided for convenience only and do not in any manner serve as an endorsement of those Web sites. The materials at those Web sites are not part of the materials for this IBM product and use of those Web sites is at your own risk. IBM may use or distribute any of the information you supply in any way it believes appropriate without incurring any obligation to you. Information concerning non-IBM products was obtained from the suppliers of those products, their published announcements or other publicly available sources. IBM has not tested those products and cannot confirm the accuracy of performance, compatibility or any other claims related to non-IBM products. Questions on the capabilities of non-IBM products should be addressed to the suppliers of those products. This information contains examples of data and reports used in daily business operations. To illustrate them as completely as possible, the examples include the names of individuals, companies, brands, and products. All of these names are fictitious and any similarity to the names and addresses used by an actual business enterprise is entirely coincidental.

Any performance data contained herein was determined in a controlled environment. Therefore, the results obtained in other operating environments may vary significantly. Some measurements may have been made on development-level systems and there is no guarantee that these measurements will be the same on generally available systems. Furthermore, some measurement may have been estimated through extrapolation. Actual results may vary. Users of this document should verify the applicable data for their specific environment.

COPYRIGHT LICENSE:

This information contains sample application programs in source language, which illustrate programming techniques on various operating platforms. You may copy, modify, and distribute these sample programs in any form without payment to IBM, for the purposes of developing, using, marketing or distributing application programs conforming to the application programming interface for the operating platform for which the sample programs are written. These examples have not been thoroughly tested under all conditions. IBM, therefore, cannot guarantee or imply reliability, serviceability, or function of these programs.

© Copyright International Business Machines Corporation 2009. All rights reserved.

Note to U.S. Government Users Restricted Rights -- Use, duplication or disclosure restricted by GSA ADP Schedule Contract with IBM Corp.

This document was created or updated on June 16, 2010.

Send us your comments in one of the following ways:

- Use the online **Contact us** review form found at:
ibm.com/redbooks
- Send your comments in an e-mail to:
redbook@us.ibm.com
- Mail your comments to:
IBM Corporation, International Technical Support Organization
Dept. HYTD Mail Station P099
2455 South Road
Poughkeepsie, NY 12601-5400 U.S.A.

This document is available online at <http://www.ibm.com/redbooks/abstracts/tips0720.html> .

Trademarks

IBM, the IBM logo, and ibm.com are trademarks or registered trademarks of International Business Machines Corporation in the United States, other countries, or both. These and other IBM trademarked terms may also be registered or common law trademarks in other countries. A current list of IBM trademarks is available on the Web at <http://www.ibm.com/legal/copytrade.shtml>

The following terms are trademarks of the International Business Machines Corporation in the United States, other countries, or both:

IBM®
Redbooks (logo)®
ServerProven®
System x®

The following terms are trademarks of other companies:

Microsoft, Windows Server, Windows, and the Windows logo are trademarks of Microsoft Corporation in the United States, other countries, or both.

Linux is a trademark of Linus Torvalds in the United States, other countries, or both.

Other company, product, or service names may be trademarks or service marks of others.